

# MODEL 172

## MOUNTING INSTRUCTIONS FOR ASTERIX SERIES ELECTRO-MAGNETIC LOCKS

**IMPORTANT! READ THOROUGHLY BEFORE ATTEMPTING INSTALLATION.**  
DO NOT DAMAGE OR MARK MAGNETIC LOCK OR ARMATURE FACE-MAY REDUCE HOLDING EFFICIENCY.

See Figure 1 elevation profiles to determine mounting application requirements for each individual application.

**NOTE:** A 2-1/2" (64 MM) REVEAL IS REQUIRED TO ASSURE RIGID MOUNTING OF THE 172 SERIES MAGNETIC LOCK ASSEMBLY.

**STEP 1.** Mark door(s) according to armature template and dimensions on reverse side.

**STEP 2.** Drill and prep holes in door per armature template on reverse side.

**STEP 3.** Gently tap (2) 3/16" (5 mm) diameter spring pins into rear side of armature(s).

**NOTE:** IF MAGNETIC LOCK ASSEMBLY IS EQUIPPED WITH BDA (BUILT-IN DELAY ACTUATOR) OPTION STOP HERE AND REFER TO INSTRUCTION SHEET MAGOPT-2 FOR INSTRUCTIONS, THEN PROCEED TO STEP 5.

**STEP 4.** Insert one (1) spring washer over 5/16"-18 "special" shoulder screw, insert screw through armature(s). Add three (3) conical spring washers and one (1) flat washer over shoulder screw(s). See Figure 2 - details for each type of installation. All parts must be assembled properly before installing armature to door. Install complete armature assembly on door per Figure 2 details.

**STEP 5.** Tighten shoulder screw(s) securely with allen wrench. (Do not overtighten.)

**NOTE:** ALL ARMATURES ARE NORMALLY EQUIPPED WITH A PERMANENT MAGNET ON ONE END. BE CERTAIN TO INSTALL ARMATURE SO MAGNET LINES UP WITH MAGNETIC SWITCH INSIDE HOUSING OF MAGNETIC LOCK ASSEMBLY. SEE FIGURE 3.

**STEP 6.** Mark frame per magnetic lock template and dimensions on reverse side.

**STEP 7.** Remove housing cover of Magnetic Lock Assembly.

**STEP 8.** Drill and prep frame per "D" of Magnetic lock template, attach Magnetic Lock Assembly to frame using either (2) #14 sheet metal screws or (2) 1/4"-20 machine screws and toothed lock washers, tighten only enough to hold unit in place. (If filler plate is used assure that screws go thru both filler plate and frame.)

**STEP 9.** Drill 7/8" (22 mm) diameter. hole thru filler plate and frame per template for wiring harness.

**STEP 10.** Make all electrical connections per applicable wiring diagrams enclosed. Use wire nuts, crimp connectors or solder to assure good connections.

**STEP 11.** Energize Magnetic Lock Assembly; Adjust assembly so door is snug against door stop, tighten (2) preliminary screws securely.

FOR BDA (Built-in Delay Actuator) OPTION: See instruction sheet MAGOPT-2.

**A.** Verify that when door is closed plunger and push button are in the closed position. If proper continuity cannot be obtained, an additional stop washer may be required to move shoulder screw further into push button switch.

**B.** Energize the system with the door in the closed position. Apply pressure to door, having retracted latch bolt (if used). Verify that compression of belleville washers and electrical state of push button switch indicates door open mode. If electrical output of switch dictates door closed condition, the shoulder screw is adjusted to far into switch, not allowing switch to return to normal position. Stop washer may have to be removed to obtain proper operation.

**C.** After all adjustments have been made, verify that switch indicates both door closed and attempted exit.

For MBS (Magnetic Bond Sensor) additional wiring details, see instruction sheet MAGOPT-1.

**STEP 12.** De-energize system. Using mounting plate as template, drill #21 drill and tap for 10-32 screws (minimum (2) places). (See Magnetic Lock Template) Install screws and tighten securely. Re-energize system, recheck alignment of Magnetic Lock Assembly to Armature by opening and closing door(s).

**STEP 13.** Install Magnetic Lock housing cover.



**ARMATURE LOCATION**

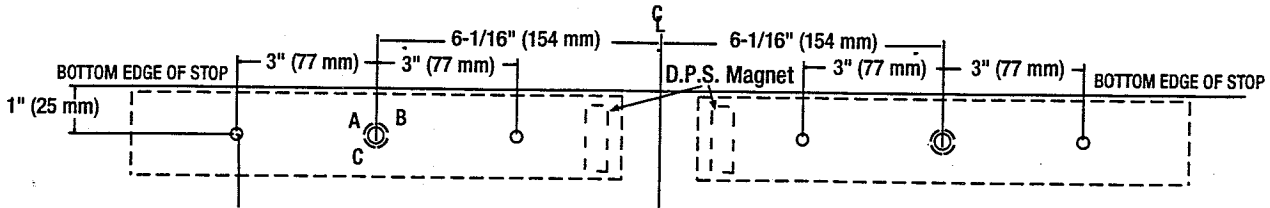

.250 (6 mm) DIA. 3/4" (19 mm) DEEP  
 NOTE: SPRING PINS OF (2) PLACES  
 EACH DOOR ARMATURE MUST FLOAT  
 FREELY INSIDE HOLES.

- A. For THRU BOLT mounting in hollow metal door(s) drill 11/32" (9 mm) DIA. hole thru door, enlarge hole in outside face to 1/2" (13 mm) DIA.
- B. For THRU BOLT mounting in solid core wood door(s), drill 11/32" (9 mm) DIA. hole thru door(s), enlarge hole in outside face to 1/2" (13 mm) DIA. 1" (25 mm) deep.
- C. For REINFORCED DOOR (Minimum 3/8" (10 mm) thickness) drill and tap thru reinforcement for 5/16-18 screw.

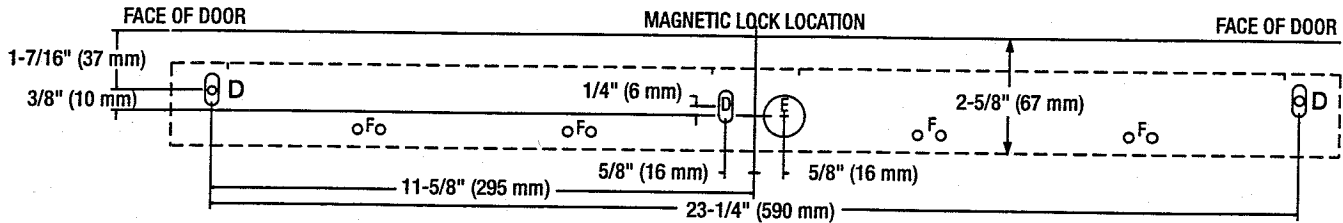

- D. Drill for No. 14 sheet metal screws or drill and tap for 1/4"-20 machine screws.
- E. Drill 7/8" (22 mm) DIA. hole thru filler (if used) and frame for wiring harness.
- F. Using actual Magnetic Lock as template, drill and tap per STEP 12 of installation instructions.

**NOTE: FOR MACHINE SCREW MOUNTING; REINFORCEMENT AND STRUCTURING ARE REQUIRED TO WITHSTAND A 1200 LB (544 KG) LOAD. CLEARANCE HOLES FOR FILLER PLATE TO BE SPOTTED AT JOB SITE. CAUTION: "DO NOT ATTACH MOUNTING PLATE TO FILLER PLATE ONLY!"**

**MAGNETIC LOCK MOUNTING TO FRAME FIGURE 1**

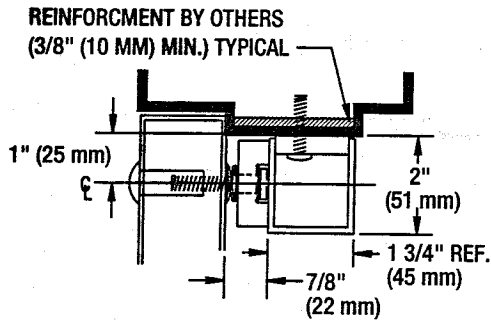

FIGURE 1A STANDARD INSTALLATION

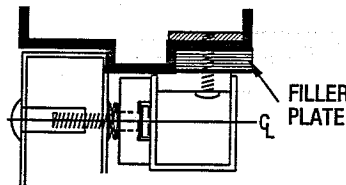

FIGURE 1B WITH SERIES 178 FILLER PLATE

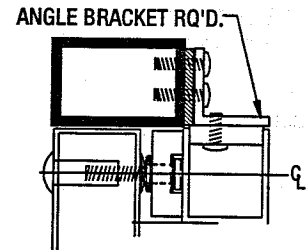

FIGURE 1C WITH 179 SERIES ANGLE BRACKET

**ARMATURE MOUNTING TO DOOR(S) FIGURE 2**

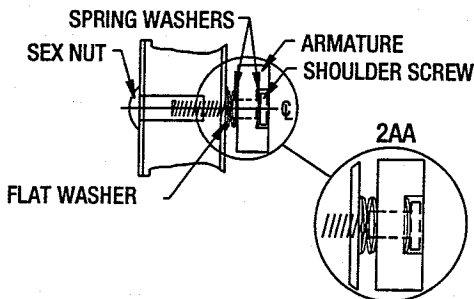

FIGURE 2A HOLLOW METAL DOOR

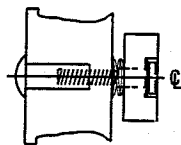

FIGURE 2B WOOD DOOR

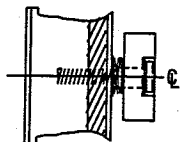
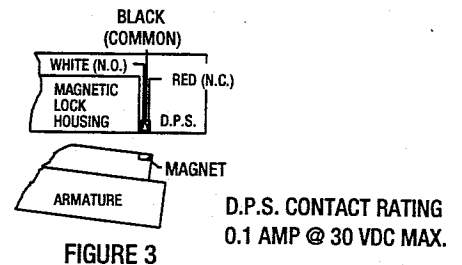

FIGURE 2C REINFORCED DOOR



WIRING FOR D.P.S (DOOR POSITION SWITCH).  
 DRAWING SHOWS DOOR IN OPEN POSITION

**ELECTRICAL SPECIFICATIONS:**  
 CURRENT DRAW: 0.50 AMPS @ 12 VDC  
 0.25 AMPS @ 24 VDC  
 WIRE COLOR CODE: ORANGE/ORANGE (12VDC)  
 (NON-POLARIZED) RED/RED (24VDC)  
 HOLDING FORCE: 1200 LB (544 KG)

**NOTE:** Use with Underwriters Laboratories  
 Listed (ULC/UL) Compatible Power Supply

\*NOTE: NOT TO SCALE



**ASTERIX SECURITY  
 HARDWARE INTERNATIONAL INC.**  
 7045 Tranmere Drive Unit 10  
 Mississauga Ontario Canada L5S 1M2  
 Phone: (905) 672-1245 Fax: (905) 672-1247  
 U.S. Phone/Fax.: (630) 350-7599