

# ACSI MODEL 1406-04-AO POWER SUPPLY INSTALLATION INSTRUCTIONS

### Features:

- Up to 2.0 Amps Load Capacity
- Class 2 Rated Outputs
- Overload, Over Voltage, and Short Circuit Protection
- Two Output Devices Controlled by One Input or Programmed for Independent Control
- Two Independent Outputs for Automatic Door Operator Interface
- Input for Connection to Fire Alarm
- Auxiliary Outputs for Powering Stand Alone Devices, Such as Keypads, Motion Detectors, and Status Indicators
- UL Listed and Tested to 294 Standard for Access Control System Units with Security Levels Rated I for Physical Attack, IV for Endurance, I for Line Security, I for Standby Power



### INSTALLATION

Transformer Model BE31763001 by Basler Electric, Transformer Model 2010028 by Galaxy Transformer and Magnetics, and Transformer Model A41-130-28A34 by EWC have been certified for UL applications.

The 1406 enclosure should be securely fastened to the wall using the four 1/4 inch diameter mounting holes located in the back of the box. Position the enclosure so that the transformer is located on the left-hand side. The 1406 must not be installed outdoors.

For the 120VAC power input, terminal block TB1 will accommodate up to 12 AWG wire (solid). Conduit must be used to provide an adequate earth ground to the enclosure.

NOTE: The maximum input current is 750mA.

The 1406 is designed to be used with all exit devices modified for 1550C electric latch retraction. Use the chart below to determine the correct wire gauge per given length of two-conductor cable that will be run from the 1406 to each exit device. Do not exceed the maximum length listed with each wire gauge.

WIRE GAUGE	MAXIMUM LENGTH OF TWO-CONDUCTOR CABLE
16 AWG	40 FEET
14 AWG	60 FEET
12 AWG	100 FEET

Up to two devices can be used with the 1406. If only one device is to be used, wire to the "DEVICE ONE" location at TB3, terminals 5 and 6.

NOTE: When using the 1550C exit device with red and black leads, be sure to observe polarity when connecting devices 1 and 2 to TB3. (Refer to the wiring diagram located on the lid of the controller.)

## STANDARD OPERATION

The 1406 provides a choice of two methods of electric latch retraction: Single System or Dual System.

### SINGLE SYSTEM LATCH RETRACTION

This method allows one input to control two devices sequentially. A momentary switch closure across terminals 1 and 2 of TB3 will retract DEVICE ONE first, followed by DEVICE TWO. Use this method for single door applications or on a pair of doors using a device on one or both leaves. The 1406 comes from the factory already set up for this method.

### DUAL SYSTEM LATCH RETRACTION (OPTIONAL)

This method allows independent control of DEVICE ONE and DEVICE TWO outputs by their own separate input. A momentary switch closure across terminals 1 and 2 of TB3 will retract DEVICE ONE only. A momentary switch closure across terminals 7 and 8 of TB3 will retract DEVICE TWO. No more than one device can be used per output. Use this option for applications requiring two single door systems or two pair door systems using one device on the active leaf of each pair of doors. To change over to the optional dual system latch retraction, move the program jumper PJ1 from between the middle post and the end post marked "S" (Single System) to between the middle post and the end post marked "D" (Dual System).

NOTE: When using the optional method, DEVICE ONE and DEVICE TWO can never be activated at the same time in the event that both input switches are actuated simultaneously. If this should occur, DEVICE ONE will always activate first, followed by DEVICE TWO.

When using a momentary, normally open switch for activating latch retraction, adjust pot R2 (for DEVICE ONE) or pot R4 (for DEVICE TWO) on the p.c. board to the desired latch retract delay time from 1 to 20 seconds. Turn the pot clockwise to increase the delay time.

When using normally open contacts from a keypad or card reader (with built-in time delay) or a maintain switch, turn pot R2 (or R4) fully counterclockwise to the minimum delay time (approx. 0.5 sec.). A contact closure will activate latch

retraction. Upon opening of the timed or maintained contacts, the device will latch within 0.5 second.

## 1550C ELR SOLENOID ASSEMBLIES - THEORY OF OPERATION

ACSI provides two types of 1550C ELR (electric latch retraction) devices: One type is designed to fit inside exit devices of narrow height and depth (1-1/4"). The leads to these devices are polarized: Red lead = (+); Black Lead = (-). The other type ELR device will fit into exit devices having a minimum height and depth of 1-1/2". The leads to these devices are non-polarized and colored blue.

### 1550C ELR Device with Polarized Leads:

This device contains a pulse module which delivers a pulse at approx. 24VDC to a high current coil inside the exit device every 6 seconds until the latch is finally pulled back all the way. At this point, a control rod passes over a reflective sensor and signals the module to stop pulsing. There is always an initial pulse that occurs at the moment the system is activated. During the period the system remains activated, output voltage is applied to a low current secondary coil. This coil is responsible for holding the latch in the retracted position until instructed to return to the "fail secure" position. (See note 2 on page 7.) The device contains a fuse to protect the ELR circuit in the event of a reversed polarity wire connection.

### 1550C ELR Device with Non-polarized Leads:

This device contains a powerful solenoid that performs both pulling and holding functions. An initial high current pulse occurs each time output voltage is applied to the device. After the pulse, the solenoid switches over to a "holding" state by way of frequency modulation which reduces the current to allow the solenoid to run at a cooler temperature. Because of its non-polar design, the device contains no fuse.

## OPERATION WITH AUTOMATIC DOOR OPERATOR

The 1406 is provided with two outputs (one output associated with DEVICE ONE and the other output associated with DEVICE TWO) for controlling separate automatic door operators. Each output consists of normally open relay contacts that are field wired directly to the "DOOR ACTIVATION" input of the automatic door operator. These outputs are activated within a moment after activation of their corresponding devices to allow time for the doors to be fully unlatched before automatic opening begins.

Time delay pots R2 and R4 are factory set at 5 seconds, which are appropriate when using this controller with automatic door operators. When the delay times out, power is removed from the exit device and the signal to the auto door

operator input is terminated, thus allowing the operator's "DOOR HOLD OPEN" delay to time out and close the door.

NOTE: When using the single system latch retraction method with automatic door operator interface and both devices are being used, the operator control input must be wired to the 1406 automatic door operator output for DEVICE TWO (TB3, terminals 9 and 10).

## OPERATION WITH FIRE ALARM

The 1406 can be wired to the fire alarm relay normally closed contacts. When a fire alarm occurs, any door that is currently unlatched, whether by momentary time delay or by maintained switch, will immediately latch secure. During the time that the fire alarm is active, electronic control of the automatic door opening system by wall switch, card reader, keypad, etc., is disabled. The door can then only be opened manually.

The 1406 comes from the factory set up for use without fire alarm interface. If the fire alarm is to be used with this controller, move program jumper PJ2 from between the middle post and the end post marked "FA DIS" (Fire Alarm Disabled), to between the middle post and the end post marked "FA EN" (Fire Alarm Enabled).

NOTE: The current drawn through fire alarm relay contacts will be 120mA @ 24VDC

## AUXILIARY POWER SOURCE OUTPUTS

Two constant, power limited auxiliary outputs are provided for powering keypads, motion sensors, annunciator panels, electromagnetic door holders, relays, LEDs, etc. Choose between auxiliary output #1 or auxiliary output #2.

- Auxiliary Output #1 Range: 26.7V - 28.0V, Nominal
- Auxiliary Output #2 Range: 12.6V - 16.5V, Nominal

NOTE: Both auxiliary outputs can be used at the same time for loads requiring different voltages (for a combined maximum load current of 500mA). However, do not tie the aux. output #2 ground (TB3, terminal 18) common to the aux. output #1 ground (TB3, terminal 16). Both of these power sources must be isolated from each other.

CAUTION: IT IS RECOMMENDED TO USE OUTPUT #2 WITH EQUIPMENT THAT HAVE INPUTS RATED FOR 12 - 24 VOLTS, AC OR DC. CHECK WITH THE MANUFACTURER BEFORE CONNECTING 24VDC RATED EQUIPMENT ACROSS OUTPUT #1 TO ENSURE THE HIGHER VOLTAGE WILL NOT CAUSE ANY DAMAGE.

## TROUBLESHOOTING

Before proceeding through the troubleshooting section, ensure that all device latches are not binding against their corresponding strikes. A bound latch can cause sluggish electric retraction or prevent retraction entirely.

### Power Limited Outputs

All outputs to the 1406 are power limited. Depending on the output, if a short circuit or an over load condition should occur, the output will either shut off entirely or go into a safe current limiting state.

**IMPORTANT!: THE MAXIMUM RATED LOAD FOR ALL OUTPUTS COMBINED IS 2.0 AMPS, INCLUDING 250mA (MAX.) FOR EACH AUXILIARY OUTPUT.**

The outputs to ELR Device One (TB3, terminals 5 & 6) and ELR Device Two (TB3, terminals 11 & 12) will completely shut down to 0 volts when a short circuit across the output occurs or when the load exceeds 5 amps. To reset the output, the short circuit or overload must first be located and removed. Next, momentarily switch off the outputs by opening the contacts across input terminals 1 & 2 or 7 & 8, whichever is used. Before switching outputs back on, ensure the load does not exceed the maximum current ratings.

Both auxiliary outputs will go into a current limiting state when the load exceeds approximately 2.0 amps or in the event of a short circuit. The current is reduced to a safe level when either of these conditions occur. The output voltage will automatically return to its normal level when the short circuit or overload condition is removed and replaced by a load falling under the maximum current rating.

### Symptom:

Neither DEVICE ONE nor DEVICE TWO retracts after the control switch is activated.

#### Possible Causes:

1. The power limited output to Device 1 or Device 2 (or both) may have shut down. When this happens, the field wires that are run to the exit device are probably shorted together against the conduit, door frame or electric hinge.
2. If using the 1550C ELR device with polarized leads, the slow blow 4 amp fuse (Littlefuse #239.004) inside the exit device may have blown. The most likely cause would be reversed polarity of the exit device red and black leads: RED = "+"; BLACK = "-". (Refer to the wiring diagram for proper connection.) Other possible causes may be shorted wires in the solenoid assembly or a defective pulse module.
3. An open connection in the field wiring between the power supply and control switch used for activating latch retraction.
4. A defective control switch.
5. An open connection in the field wiring between the power supply and exit device.
6. There may be no pulse. To check for pulses, prop the door open and connect a voltmeter across the red and black leads coming from the exit device (red lead is positive), or across the blue leads if using the alternate non-polarized 1550C ELR device . Next, connect a jumper wire across terminals 1 and 2 of TB3 to keep DEVICE ONE in a continuous retracted state. If the voltmeter measures between 30 and 40 VDC at the moment the jumper wire was installed, but the latch did not budge, then no initial pulse was generated. For the polarized 1550C ELR device, check for a series of timed pulses that will occur approximately every six seconds. (Make sure that the control rod is not positioned over the reflective sensor on the pulse module when making this next check.) Wait for about 20 seconds to see if the latch pulls in. If it still does not respond, then it indicates the pulse module is inoperative and the entire solenoid/module assembly must be replaced.

#### Symptom:

When 120 volts is applied to TB1, the exit devices immediately retract, even though the control switch had not been activated.

#### Possible Causes:

1. Field wiring between the power supply and control switch are shorted together against the conduit or switch mounting box.
2. A maintain switch is being used and is in the closed position.

3. A defective control switch.

Symptom (for polarized 1550C ELR devices only):

A noticeable buzzing sound at equal intervals is coming from inside the exit device when activated.

Possible Causes:

1. The latch is binding against its corresponding strike and preventing it from fully retracting, due to misalignment between the latch and strike opening.
2. A defective pulse module

**For Service or Technical Support, call Architectural Control Systems, Inc. at (800) 753-5558.**

NOTE 1: THIS UNIT IS LISTED AS AN EXIT DEVICE CONTROL UNIT TO UL294 REQUIREMENTS.

NOTE 2: THE POWER OUTPUT OF THE CONTROLLER IS OF A FAIL SECURE DESIGN. THE EXIT DEVICE REMAINS LATCHED DURING A COMPLETE POWER FAILURE, BUT ALWAYS ALLOWS FREE MECHANICAL EGRESS. LISTED PANIC HARDWARE MAY BE REQUIRED TO ALLOW EMERGENCY EXIT. CONSULT LOCAL AUTHORITY HAVING JURISDICTION.



120 VAC 60 HZ.  
POWER INPUT.  
750mA MAXIMUM.  
12 AWG MAXIMUM  
WIRE SIZE.

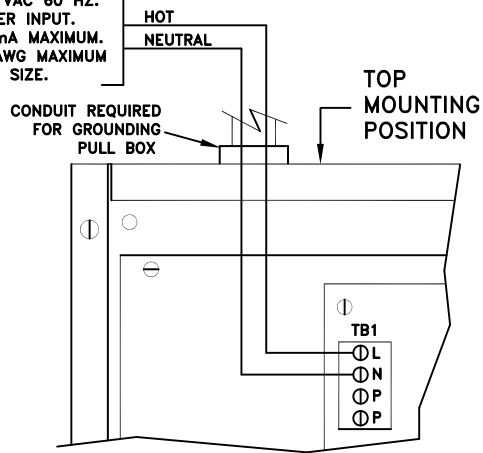

# GENERAL WIRING DIAGRAM FOR 1406-04-AO ELECTRIC LATCH RETRACTION CONTROLLER

USE INSTALLATION INSTRUCTIONS  
II - 1400-2

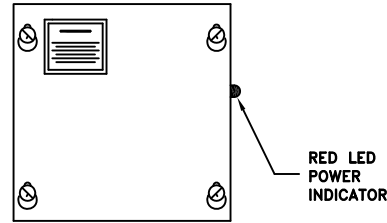

CLASS 2 OUTPUTS

SECURITY



LISTED  
EQUIPMENT  
4M73

ACCESS CONTROL POWER SUPPLY, ACCESS CONTROL  
ELECTRIC LATCH RETRACTION (ELR) CONTROLLER

CONTROLLER INTENDED  
FOR INDOOR USE ONLY.



USED FOR ADJUSTING UNLOCK DELAY TIME WHEN  
USING MOMENTARY ACTION SWITCHES FOR SW. 1 AND  
SW. 2. R2 ADJUSTS DEV. 1 (SINGLE DOOR) OR DEV.  
1 & DEV. 2 (PAIR DOORS) TIME DELAY. R4 ADJUSTS  
DEV. 2 (SINGLE DOOR) TIME DELAY. 20 SEC. MAX.  
DELAY TIME.

MFG. DATE:

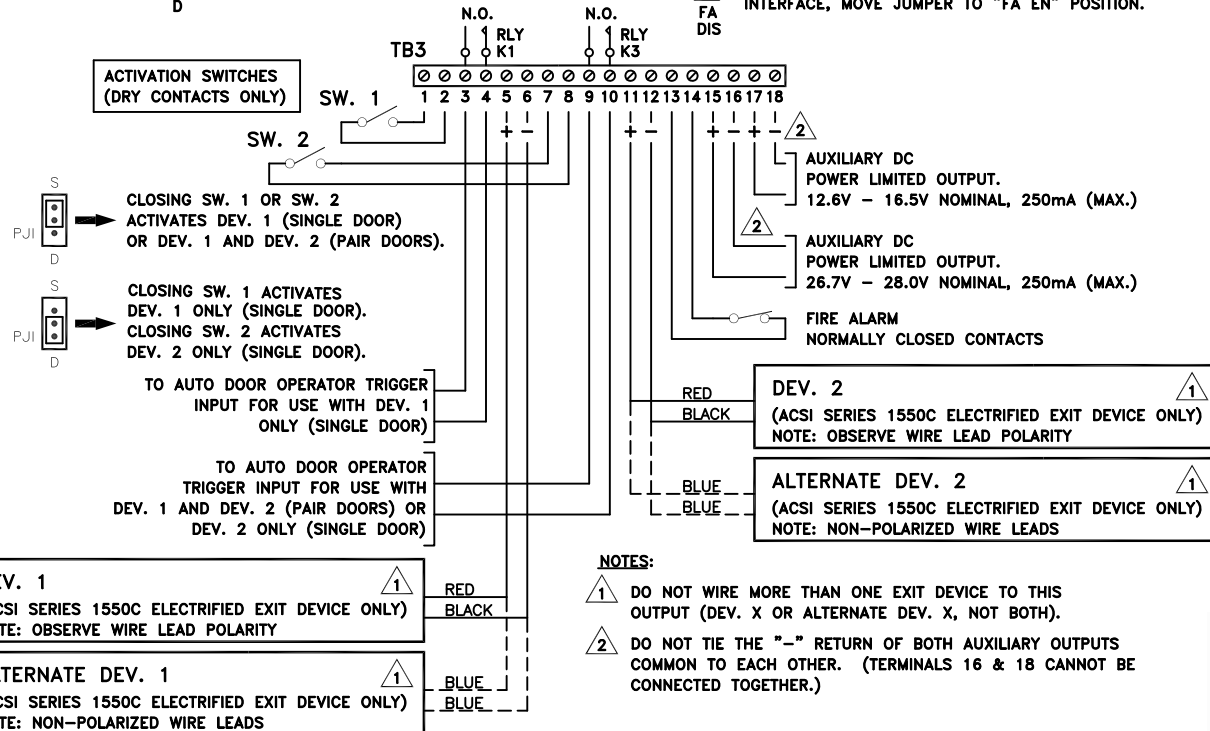
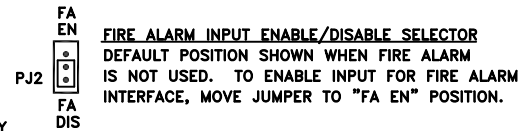

- NOTES:**
- 1 DO NOT WIRE MORE THAN ONE EXIT DEVICE TO THIS OUTPUT (DEV. X OR ALTERNATE DEV. X, NOT BOTH).
  - 2 DO NOT TIE THE "-" RETURN OF BOTH AUXILIARY OUTPUTS COMMON TO EACH OTHER. (TERMINALS 16 & 18 CANNOT BE CONNECTED TOGETHER.)

FOR TROUBLE SHOOTING ASSISTANCE,  
CONTACT ACSI TECHNICAL SUPPORT:  
1-800-753-5558

REV. 06/15

